

45-48	6
30-44	1
DOOR OPNG.	T

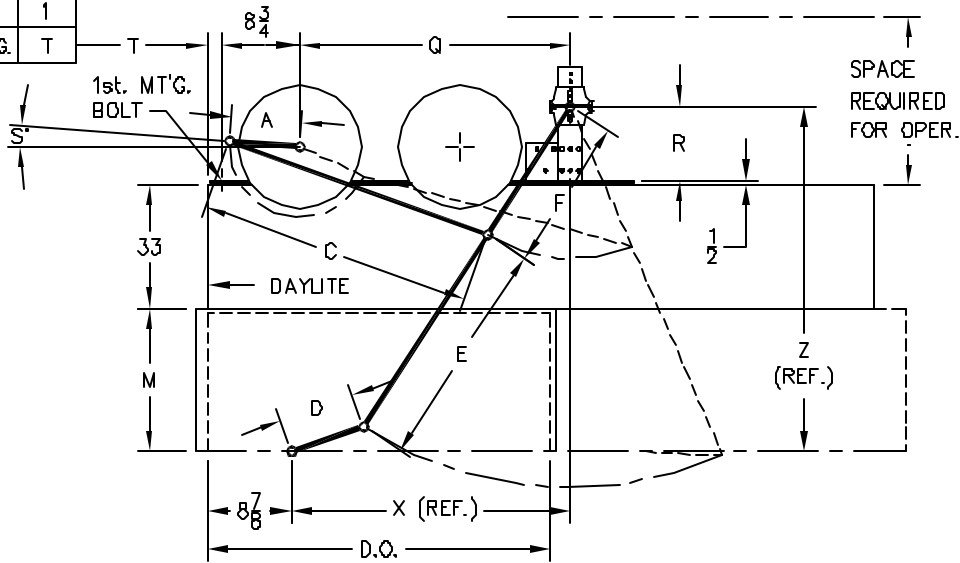

MOVFR	15
MOCT MOD	
MOM-MOH	19
MOMCT MOHCT	

48	7 <sup>3</sup> / <sub>8</sub>	34 <sup>7</sup> / <sub>8</sub>	12	48	21	23	39 <sup>5</sup> / <sub>8</sub>	67	33 <sup>1</sup> / <sub>2</sub>	10 <sup>1</sup> / <sub>2</sub>	5'
47	7 <sup>1</sup> / <sub>4</sub>	34 <sup>3</sup> / <sub>4</sub>	12	48	21	23	39 <sup>5</sup> / <sub>8</sub>	67	33 <sup>1</sup> / <sub>2</sub>	10 <sup>1</sup> / <sub>2</sub>	5'
46	7 <sup>1</sup> / <sub>8</sub>	34 <sup>5</sup> / <sub>8</sub>	12	48	21	23	39 <sup>5</sup> / <sub>8</sub>	67	33 <sup>1</sup> / <sub>2</sub>	10 <sup>1</sup> / <sub>2</sub>	5'
45	7	34 <sup>1</sup> / <sub>2</sub>	12	48	21	23	39 <sup>5</sup> / <sub>8</sub>	67	33 <sup>1</sup> / <sub>2</sub>	10 <sup>1</sup> / <sub>2</sub>	5'
44	7 <sup>3</sup> / <sub>8</sub>	36 <sup>3</sup> / <sub>8</sub>	10	41	21	19	34 <sup>5</sup> / <sub>8</sub>	60 <sup>1</sup> / <sub>8</sub>	33 <sup>1</sup> / <sub>2</sub>	7 <sup>5</sup> / <sub>8</sub>	12'
43	7 <sup>1</sup> / <sub>8</sub>	36 <sup>1</sup> / <sub>4</sub>	10	41	21	19	34 <sup>5</sup> / <sub>8</sub>	60 <sup>1</sup> / <sub>8</sub>	33 <sup>1</sup> / <sub>2</sub>	7 <sup>5</sup> / <sub>8</sub>	12'
42	7	36 <sup>1</sup> / <sub>8</sub>	10	41	21	19	34 <sup>5</sup> / <sub>8</sub>	60 <sup>1</sup> / <sub>8</sub>	33 <sup>1</sup> / <sub>2</sub>	7 <sup>5</sup> / <sub>8</sub>	12'
41	6 <sup>7</sup> / <sub>8</sub>	36	10	41	21	19	34 <sup>5</sup> / <sub>8</sub>	60 <sup>1</sup> / <sub>8</sub>	33 <sup>1</sup> / <sub>2</sub>	7 <sup>5</sup> / <sub>8</sub>	12'
40	6 <sup>3</sup> / <sub>4</sub>	35 <sup>7</sup> / <sub>8</sub>	10	41	21	19	34 <sup>5</sup> / <sub>8</sub>	60 <sup>1</sup> / <sub>8</sub>	33 <sup>1</sup> / <sub>2</sub>	7 <sup>5</sup> / <sub>8</sub>	12'
39	6	30 <sup>1</sup> / <sub>2</sub>	8	40	18	15	29 <sup>1</sup> / <sub>4</sub>	56 <sup>1</sup> / <sub>2</sub>	28 <sup>3</sup> / <sub>8</sub>	8	10'
38	5 <sup>7</sup> / <sub>8</sub>	30 <sup>3</sup> / <sub>8</sub>	8	40	18	15	29 <sup>1</sup> / <sub>4</sub>	56 <sup>1</sup> / <sub>2</sub>	28 <sup>3</sup> / <sub>8</sub>	8	10'
37	5 <sup>3</sup> / <sub>4</sub>	30 <sup>1</sup> / <sub>4</sub>	8	40	18	15	29 <sup>1</sup> / <sub>4</sub>	56 <sup>1</sup> / <sub>2</sub>	28 <sup>3</sup> / <sub>8</sub>	8	10'
36	5 <sup>5</sup> / <sub>8</sub>	30 <sup>1</sup> / <sub>8</sub>	8	40	18	15	29 <sup>1</sup> / <sub>4</sub>	56 <sup>1</sup> / <sub>2</sub>	28 <sup>3</sup> / <sub>8</sub>	8	10'
35	5 <sup>1</sup> / <sub>2</sub>	30	8	40	18	15	29 <sup>1</sup> / <sub>4</sub>	56 <sup>1</sup> / <sub>2</sub>	28 <sup>3</sup> / <sub>8</sub>	8	10'
34	5 <sup>1</sup> / <sub>8</sub>	26	6	42	17	15	25 <sup>1</sup> / <sub>4</sub>	57 <sup>3</sup> / <sub>4</sub>	24 <sup>3</sup> / <sub>8</sub>	9 <sup>1</sup> / <sub>4</sub>	10'
33	4 <sup>3</sup> / <sub>4</sub>	25 <sup>7</sup> / <sub>8</sub>	6	42	17	15	25 <sup>1</sup> / <sub>4</sub>	57 <sup>3</sup> / <sub>4</sub>	24 <sup>3</sup> / <sub>8</sub>	9 <sup>1</sup> / <sub>4</sub>	10'
32	4 <sup>5</sup> / <sub>8</sub>	25 <sup>3</sup> / <sub>4</sub>	6	42	17	15	25 <sup>1</sup> / <sub>4</sub>	57 <sup>3</sup> / <sub>4</sub>	24 <sup>3</sup> / <sub>8</sub>	9 <sup>1</sup> / <sub>4</sub>	10'
31	4 <sup>1</sup> / <sub>2</sub>	25	6	42	17	15	24 <sup>3</sup> / <sub>8</sub>	58	23 <sup>1</sup> / <sub>2</sub>	9 <sup>1</sup> / <sub>2</sub>	10'
30	4 <sup>3</sup> / <sub>8</sub>	24 <sup>7</sup> / <sub>8</sub>	6	42	17	15	24 <sup>3</sup> / <sub>8</sub>	58	23 <sup>1</sup> / <sub>2</sub>	9 <sup>1</sup> / <sub>2</sub>	10'
INCHES	A	C	D	E	F	M	X	Z	Q	R	S
DOOR OPENING	OPERATOR ARMS		DOOR ARMS			CLUTCH	PIVOT		OPERATOR		



SINGLE SPEED & TWO SPEED OPERATOR DATA TABLE  
30-48 D.O. FOR HIGH CABS 33" HEADER

FEB. 23 1987

S6898-33